



BGA ENGINEERING

NEWS

Number 6, May 2001

FOOT AND MOUTH

The Foot and Mouth crisis is effecting everyone. Some of you have been unable to get near your aircraft due to local restrictions and some annual inspections have been delayed. The BGA understand the difficulties and will be flexible in authorising C of A extensions when necessary. Please apply to the CTO, by e-mail if possible, or letter.

I was pleased to see some very responsible measures being taken, on a recent visit to the Severn valley, to discharge our legal and moral responsibilities to the farming community. We all know it is difficult but keep it up as we rely on the goodwill of farmers to allow us to land in their fields when necessary.

As flying has been necessarily reduced in recent months and will probably be somewhat restricted for the foreseeable future you may have some spare time on your hands. After you have decorated that back bedroom you promised to do two summers ago, it may be a good time to

stand back and look at your workshop.

Be ruthless and throw away all that old junk you have been keeping for years (just in case!) It was probable removed because it was worn out anyway.

Spring is here!

Yes that time of year is here again and gliders will (hopefully) be coming out of hibernation. Watch out for prospective parents of the creepily-crawley variety making homes inside instrument tubes and the like.

Don't forget the furry and feathered variety as well. In this months GASIL there is a picture of a motor glider (T61) with at least 5, yes **five**, large nests inside the wings.

It involved extensive cutting to gain access and remove the offending items. The question of corrosion needs to be considered as a result of the droppings. I suggest you pick up your clubs copy and read it.

One point not covered in the article; birds bring grubs to feed their young, some of these escape.

Q. What food do tree boring grubs love?

A. Wood.

Q, What material is your spar and ribs made from?

A. Wood.....

AAIB Visit

I had occasion to visit the AAIB (Air Accidents Investigation Branch) at Farnborough to assist, in a small way, the investigation into a recent Glider accident.

While I was there the sights seen were truly amazing. Wreckage was strewn all over the large hangar each segregated into different projects. Most of the events you see on the news were there. Some aircraft were rebuilt into a strange 3D mosaic jigsaw's at a point frozen in time of the actual occurrence. Some of the pieces were not recognisable as parts of aircraft. I believed until that point that parts of wreckage would be easily recognisable, I now know better!

I believe we all owe a great deal of gratitude to this dedicated team of investigators who will not stop until the cause of an accident is answered as fully as possible.

They are not there to apportion blame but unfortunately sometimes that is the eventual outcome.

BGA Exposition

Progress report:

We had a 2-day consultation meeting with the CAA at Leicester in April.

The basic principles of the BGA Exposition were discussed and agreed. We will face some tightening of procedures, changes in the way CAA C of A are issued and renewed (see notice in TNS) but on the other hand will allow the BGA, with the proper control, more scope in our maintenance activities. Tug maintenance being one of the big changes, along with the possibility of Motor Glider engine overhaul.

I am unable to give specifics at this stage, as the proposals have to be approved by the BGA Executive and be submitted formally to the CAA for approval.

As soon as we have something concrete to publish we will do so.

BGA Charges

Some charges have risen. Please see the Notice in the TNS.

We are getting more and more requests to issue

replacement C of A's for gliders. We suspect this is because "Owners" are not looking after them, as they should. This is an important document and to replace it involves a great deal of administration work. It also causes confusion when the "old" C of A is found and then used for a renewal.

BGA 30 Day tickets

Reminder

There are strict rules on the application of BGA 30 day tickets.

For the record:

BGA 30 Day tickets may only be issued to BGA approved Gliders holding a BGA C of A.

Extension to BGA C of A by application of a 30 day ticket can only be authorised by the CTO.

BGA Accident/Incident reports

There is a revised form in use now. But,

Please, enter the aircraft details fully and correctly before submission to the BGA.

We have had a large number of reports in recent months sent in without the BGA number etc. Some with "dub K13". I am sure you know which aircraft it is but we certainly do not!

We waste a lot of time chasing this information and while doing that we are not

doing something else. (Like processing your C of A)

Please pass this message on to your Safety Officer.



Good Idea.

On a recent visit to the RAF GSA at Bicester I observed a novel idea to solve the problem of inflating tyres away from the hangar and avoiding the dreaded foot pump!

They had constructed a portable self contained tyre inflation unit containing the innards of one of those car plug in tyre pumps and hose coupled to a spare glider battery with a fuse and switch. The whole lot was housed in a neat aluminium carry tray 9"x6".

Just take it to your trailer or glider; connect up and hey-presto, inflation.

After use the battery can be charged along with the other glider batteries.

Please, send or tell me about any articles, ideas etc. for inclusion in this newsletter.

Thanks.

Jim Hammerton CTO
New Mobile code;
07710 871039

- 1.14 **LET L13 Blanik** BGA 012/03/2001 issue 1 (Mandatory)
Fuselage – Bulkhead 13 Cracking.
Details enclosed
- 1.15 **PIK 20E** Reportable accident AAIB Conclusion
Propeller hub separation from the Rotax 501 engine by loosening of hub nut
The precise reason is unresolved. Reminder to monitor and comply with AD90-239.
- 1.16 **Rolladen-Schneider LS6** TB6035 AD2001-110 (Mandatory)
Extension of service time and supplements of the Maint. Manual.
Detail enclosed.
- 1.17 **Rolladen-Schneider LS6** TB6036/2 AD1999-266/2 (Mandatory)
Obstruction of emergency canopy jettison and avoidance
Possible injuries.
Details enclosed.
- 1.18 **Rolladen-Schneider LS7** TB7011/2 AD1999-267/2 (Mandatory)
Obstruction of emergency canopy jettison and avoidance
Possible injuries.
Details enclosed.
- 1.19 **Rolladen-Schneider LS8** TB8004/2 AD1999-268/2 (Mandatory)
Obstruction of emergency canopy jettison and avoidance
Possible injuries.
Details enclosed.
- 1.20 **Schempp-Hirth Discus-2a/2b** TN360-15
Wingtip with winglets. S/N 1 > 12.
- 1.21 **Schempp-Hirth Discus-2a/2b** TN360-16
Wingtip with winglets S/N 13 > 97.
- 1.22 **Schempp-Hirth Ventus-2cM** TN825-25
Noise Certificate S/N 44 & 46 > 95.
- 1.23 **Schempp-Hirth Ventus-bT, cT.** TN825-26
Fuel shut off valve control & Fuel tank locking device.
- 1.24 **Schleicher ASW 24** Reported by London Sailplanes
Aileron hinges found dis-bonded from wing. Suspect cause – over tight hinge pins
or towing with 'one man' wing wheel dolly over rough ground.
- 1.25 **Schleicher ASK13 & 18** (BGA 010/12/2000 issue 1 refers)
To assist with the rectification of out of tolerance elevator drive engagement
condition, Schleicher has made available non-drilled elevator arms and fin brackets.
In addition they will manufacture special one off brackets. These parts are available
through the UK agent.
The BGA have also approved the fitting of a spacer of up to 6mm between the fin
and the bracket to move the pivot forward. See section 2.
- 1.26 **Slingsby T65 Vega** BGA 013/03/2001 issue 1 (Mandatory)
Flying controls – Elevator Disconnection and Tailplane Attachment
Details enclosed (including a reprint of TI No 104/T65 Iss.2)

- 1.27 **Stemme S10-V and VT** TBA31-10-001 AD1999-224/5 (Mandatory)
Variable Pitch Propeller fork replacement.
Details enclosed.
- 1.28 **SZD 51-1 Junior** BGA 014/03/2001 issue 1 (Mandatory)
Flying Controls – Rudder pedal adjustment.
Details enclosed.
- 1.29 **SZD 51-1 Junior** BGA 015/04/2001 issue 1 (Mandatory)
Inspection of air brake gears and pre-flight inspection guidelines.
Details enclosed
- 1.30 **SZD 50-1 & 50-3 Puchacz** BGA 016/04/2001 issue 1 (Mandatory)
Inspection of air brake gears and pre-flight inspection guidelines.
Details enclosed
- 1.31 **SZD ALL with Nylon gears** BGA 017/04/2001 issue 1 (Mandatory)
Except: SZD 50-1 & 50-3 Puchacz and SZD 51-1 Junior
Inspection of air brake gears and pre-flight inspection guidelines.
Details enclosed
- 1.32 **SZD 9 Bocian** Reportable accident at The Park
Rear canopy unlatched during flight. Latching mechanism modified to standard of
1E Bocian to prevent reoccurrence.
- 1.33 **Valentin Mistral-c** TN329-013 AD2001-089 (Mandatory)
Ailerons. Residual momentum of ailerons.
Details enclosed
- 1.34 **Stainless Steel Control Cables**
Piper have issued a service bulletin No 1048 after investigation into the use and
maintenance of SS control cables. Piper consider that Stainless Steel cables have a
considerably shorter service life than galvanised cables. Piper recommends
lubrication with Aeroshell 33 or equivalent where a cable passes over a pulley or
through a fairlead. A good quality general purpose grease would be a suitable
equivalent to Aeroshell 33 for use on BGA gliders.
- 1.35 **Rotax 912 & 914 series.** SB-912-022, SB-914-011
Replacement of valve spring retainer on single valve spring engines.
(Rotax consider this SB Mandatory)

Part 2 Modifications

	Type:	Subject:	Mod No:	Contact:
2.1	Janus C	Tailwheel	BGA 2001/01	Southern Sailplanes
2.2	K7	Tailwheel	BGA 2001/02	BGA
2.3	Lunak	Smoke Canister	BGA 2001/03	BGA
2.4	Junior	Trimmer rod	BGA 2001/04	BGA
2.5	DG505	Dynafoam seat	BGA 2001/05	On test
2.6	Pirat	Control bearings	BGA 2001/06	BGA
2.7	Kestrel 19	Wing Fences	BGA 2001/07	BGA
2.8	Carmam M200	Airbrake cap Strips	BGA 2001/08	BGA
2.9	ASK13	Canopy external release	BGA 2001/10	Severn Valley SP
2.10	PIK20d	Mylar seals	BGA 2001/11	BGA

2.11	Pilatus B4	Reposition U/C Switch	BGA 2001/12	BGA
2.12	LS3	Tailwheel	BGA 2001/13	BGA
2.13	Vega	Pilot relief tube	BGA 2001/14	BGA
2.14	Junior	Rudder pedal tube reinf.	BGA 2001/15	BGA
2.15	ASK 13 & 18	Elevator, Fin bracket	BGA 2001/16	BGA – Details enclosed

Part 3 General Matters

3.1 **Using glider rudders as a lifting handle!**

I have had a report from a member of the Vintage Glider club that he has observed many gliders being man handled in and out of their trailers lifted by their rudders. This applies equally to modern and vintage gliders alike.

This is a very poor practice that should be discouraged. Many rudder hinges are made from thin or lightweight materials and use a locating peg as one or more hinges. The hinges are designed to take flight loads and can easily be bent if used to support the weight of the aircraft.

The results of a rudder coming off in flight do not need describing.

Please, in the interests of safety, advise members if you observe this practice.

3.2 **CAA Airworthiness Notices**

Now up to issue 128.

Airworthiness notices are now available on the Internet free of charge. Visit www.srg.caa.co.uk

Reminder: If you receive a copy on paper, and wish to continue to do so, follow the instructions on the Notice included in the latest issue.

3.3 **BGA Charges**

Please see enclosed notice.

3.4 **BGA and CAA Procedures for Motor Glider and Tug C of A Issue and Renewal.**

Please see enclosed notice.

3.4 **BGA 30 Day Tickets**

Please see section in BGA Engineering News, number 6.

Compliance Statement:

All mandatory inspections and modifications have been included up to the following;

Airworthiness Notices, Contents issue 128

Mandatory Aircraft Modifications & Inspections Summary, issue 246

FAA Summary of Airworthiness Directives. Bi-weekly listing 2001-08

Foreign Airworthiness Directives Vol. I and II – CAA Additional Airworthiness Directives, issue 320

Foreign Airworthiness Directives, issue 330

CAA Mandatory Permit Directives, issue Jan. 2001

Jim Hammerton
Chief Technical Officer

SAFETY REGULATION GROUP

Aviation House
Gatwick Airport South
West Sussex
RH6 0YR
UNITED KINGDOM

Direct Dial +44(0)1293 573149
Direct Fax +44(0)1293 573993
E-mail ad.unl@arg.caa.co.uk

Switchboard +44(0)1293 567171
Fax +44(0)1293 573999
Telex 878753

CIVIL AVIATION
AUTHORITY

Our ref: 9/97/7/5

23 March 2001

LETTER TO OWNERS/OPERATORS NO 2182 MAINTENANCE ORGANISATIONS AND AOC HOLDERS THE USE OF DISINFECTANTS ON LANDING GEARS, WHEELS AND TYRES

This Letter to Owners/Operators (LTO) is intended to bring to the attention of aircraft operators and maintenance organisations, the potential for airworthiness problems arising from the application of disinfectants to aircraft components and structural assemblies.

Following the outbreak of 'Foot and Mouth Disease', various authorities within the UK and in other parts of the world, have instituted procedures aimed at containing the spread of the disease. These procedures include the application of disinfecting agents to aircraft wheels and skids.

The chemical constituents of disinfectants possibly contain compounds which have the potential to cause deterioration of materials commonly encountered in the construction of aircraft undercarriages, skid assemblies and associated systems and structures: ingestion of these compounds by turbine engines could also have a deleterious effect.

Great care should be taken when applying the disinfectant to ensure that application is kept to the minimum spread consistent with the need for disinfecting.

The advice of the Type Certificate Holder should be sought in every case, regarding the use of specified disinfecting agents and their potential for harming aircraft materials. As a general rule however, the disinfecting agents need to be washed off as soon as possible once they have achieved their intended purpose.

Aircraft tyres should not suffer from exposure to the disinfecting agent. Carbon brakes and metal parts however, may be susceptible to the salt-based by-products of the disinfecting agents, and hence every effort should be made to avoid unnecessarily spraying adjacent components and structures. Carbon brake heat packs may suffer accelerated oxidation whilst metallic materials may be subject to pitting corrosion, surface corrosion and in extreme cases, hydrogen embrittlement unless corrective action is taken within an appropriate time-scale. Every effort should be made to avoid deeper penetration of the disinfecting agents into carbon heat packs where higher temperatures may exacerbate oxidation problems. The use of high pressure cleaning equipment should be avoided (unless otherwise advised by the Type Certificate holder).

Obviously, care should be taken to ensure that the disinfectant does not contaminate engines: this may be a particular problem for helicopter operators. The engine Type Certificate Holder's advice should be sought, but as a general rule, corrective action would be similar to that associated with sea-water/off-shore operations and consist of regular 'engine wash cycles'.

Aircraft operators should consult with their contracted maintenance organisation concerning the content of this LTO. Additionally, it may be necessary for operators to liaise with airport authorities to ensure that (insofar as possible) the application is confined to the minimum area necessary and also to ensure that the final cleansing process adequately fulfils its intended function.

Enquiries regarding this LTO should be referred to Dr E Blacklay, Structures and Materials Department (Telephone No 01293 573596) at the above address.



R J TEW
Applications and Certification Section

continued overleaf



INVESTOR IN PEOPLE

IMPORTANT



Safety Regulation Group

See Distribution

19 April 2001
Ref 9/99/F&M

Dear Sir

FLIGHT CREW INCAPACITATION AND OTHER IMPLICATIONS OF FOOT AND MOUTH PRECAUTIONS

In a recent Mandatory Occurrence Report made to the Authority, the single pilot of a public transport flight became so incapacitated by exposure to disinfectant fumes that he had to be hospitalised after the flight.

Brief details of the incident are as follows:

Two airports were involved and both were using MAFF recommended disinfectants. However, the first airport was using an incorrect disinfectant concentration. On the outbound leg, the pilot was required to walk through a footbath/mat impregnated with disinfectant fluid. During this procedure, the pilot's trousers/clothing were accidentally splashed with fluid due to the movement of a baggage trolley through the footbath whilst he was standing near it. During the flight the pilot became aware of disinfectant fumes. He began to feel light-headed and giddy and suffered a bad attack of disorientation/leans. The symptoms dissipated and the pilot felt well enough to continue. At the destination, the pilot tripped over a tray of a different disinfectant fluid causing further contamination to his clothing. On the flight from this airport, although initially feeling well, he was again affected by fumes, and although able to land the aircraft safely he then suffered from such severe vomiting and loss of co-ordination that he had to be hospitalised. Food or carbon monoxide poisoning have been discounted as causes of this incapacitation.

The CAA is bringing this incident to your attention and asks that you give it the widest circulation possible. Whilst it is important to co-operate with all the precautions in place to reduce the spread of foot and mouth disease, it is equally important to remember that the unwanted contamination of clothing or skin from disinfectant fluids can have additional and serious effects. Various substances are used to produce the approved disinfectants employed to counter the spread of foot and mouth disease. Many of them contain substances like formaldehyde, phosphoric acid, sulphuric acid and iodine and these in other than approved dilutions can be hazardous to both humans and aircraft structures. Aircraft operators are reminded that it is their responsibility to ensure the safety of aircraft and crews.

An earlier communication from the CAA¹ highlighted the potential for airworthiness problems arising from the application of disinfectants to aircraft components and structural assemblies. Maintenance Organisations are also requested to consider the effects of contamination on the clothing or skin of maintenance staff from disinfectant fluids, as similar symptoms may be encountered by staff when working in confined areas of aircraft. Guidance should be given to all staff working on or around aircraft where disinfectant fluids are being used to ensure they are aware of the serious effects that contamination of the skin or clothing can have.

Yours faithfully,

R C Dean
Head General Aviation Department

W J Done
Chief Surveyor

Distribution:

External:

Organisations with BCAR Approvals M3, B1, and M5, JAR145 Approvals A1, A2, and A3
AOC and PAOC Holders
General Aviation Organisations (through General Aviation Department)
Joint Aviation Authorities

Internal

Mr P Hunt, Head of Operating Standards Division
Mr M J Bell, Head of Design and Production Standards Division
Deputy Chief Surveyor
Head of Aircraft Certification Section
Head of Flight Department
Head of Propulsion Department
Head of Structures and Materials Department
Head of Safety Investigation and Data Department
CAA UK Regional Offices (Operations) - by e-mail
CAA UK Regional Offices (AMSD)
CAA Overseas Offices (AMSD)

¹ Letter to Owners/Operators No 2182 "The use of disinfectants on landing gears, wheels and tyres"

GSAC

AIRWORTHINESS DIRECTIVE

released by DIRECTION GENERALE DE L'AVIATION CIVILE

Inspection and/or modifications described below are mandatory. No person may operate a product to which this Airworthiness Directive applies except in accordance with the requirements of this Airworthiness Directive.

Translation of 'Consigne de Navigabilité' ref. : 1995-060(A) R1
In case of any difficulty, reference should be made to the French original issue.

SN CENTRAIR

Type 201 sailplanes

Extension of the service time (ATA 04)

1. AIRCRAFT CONCERNED

This Airworthiness Directive concerns type 201 A, 201 B, 201 B1 sailplanes, all serial numbers.

2. REASONS

The service time of type 201 A, 201 B, 201 B1 sailplanes may be extended to 12,000 hours provided that the special inspections described in referenced Manufacturer Service Bulletin are performed.

3. ACTIONS REQUIRED

Apply at 3,000, 4,500, 6,000, 7,500, 9,000, 10,000 and 11,000 hours the inspection programme detailed in Service Letter 201-08 Revision 1 dated November 12, 1997, available from the Manufacturer.

Record the application of this Airworthiness Directive on the aircraft logbook.

REF. : SB CENTRAIR n° 201-12 Rev. 2 dated November 18, 1997

This Revision 1 replaces original AD 95-060(A) dated March 29, 1995

EFFECTIVE DATES:

Original AD : APRIL 08, 1995
Revision 1 : APRIL 14, 2001

n/OG

April 04, 2001

SN CENTRAIR
Type 201 sailplanes

1995-060(A) R1



**Airworthiness
Directive
2001-079**

WS 03/04/01 1.5

Luftfahrt-Bundesamt
Airworthiness Directive Section
Hermann-Blenk-Str. 26
38108 Braunschweig
Federal Republic of Germany

WS 03/04/01 1.5

Glaser Dirks

Effective Date: March 08, 2001

Affected:

Kind of aeronautical product: Sailplane
Manufacturer: DG-Flugzeugbau, Bruchsal, Germany
Type: DG-500/22 ELAN
Model: all
Serial numbers affected: all
German Type Certificate No.: 348

Subject/Reason:

Ball bearings and articulated rod ends in the cockpit area.
If lubrication tasks on the ball bearings and the articulated rod ends in the cockpit area are not performed properly, this may lead to rough operation or to jamming of the bearing/articulated rod connections.

Aft control stick

Damage to or incorrect length of the retaining cables of the aft head rest may cause blocking of the aft control stick.

Action:

Lubrication of the ball bearings and articulated rod ends located below the access panels in the cockpits as well as checks of the retaining cables of the aft head rest for proper condition and correct length in accordance with the specifications of the Technical Information.

We expressly point out that nos. 2 and 4 of the manufacturer's Technical Information are not subject of this AD. The accomplishment of those items is to be considered a recommendation given by the manufacturer. The actions must be done in accordance with the Technical Note of the manufacturer.

Compliance:

Actions to be accomplished not later than March 31, 2001.

Technical publication of the manufacturer:

DG-Flugzeugbau Technical Note No. 348/15 dated January 26, 2001 which becomes herewith part of this AD and may be obtained from Messrs.:

DG-Flugzeugbau
Postbox 41 20
D- 76625 Bruchsal
Federal Republic of Germany
Phone: ++ 49 7257 890 Fax: ++ 49 7257 8922

Accomplishment and log book entry:

Action to be accomplished by an approved service station and to be checked and entered in the log book by a licensed inspector.

Holders of affected aircraft registered in Germany have to observe the following:

As a result of the a.m. deficiencies, the airworthiness of the aircraft is affected to such an extent that after the expiry of the a.m. dates the aircraft may be operated only after proper accomplishment of the prescribed actions. In the interest of aviation safety outweighing the interest of the receiver in a postponement of the prescribed actions, the immediate compliance with this AD is to be directed

Instructions about Available Legal Remedies:

An appeal to this notice may be raised within a period of one month following notification. Appeals must be submitted in writing or registered at the Luftfahrt-Bundesamt, Hermann-Blenk-Str. 26, 38108 Braunschweig.

DG Flugzeugbau GmbH
76646 Bruchsal

**Technical Note
No. 348/15**

page 1 from 1

Subject : Greasing schedule / manual revision

Effectivity : DG-500 all models, all serial no.'s

Accomplishment : 31.03.2001

Reason :

1. The greasing schedule in the maintenance manual does not point out the bearings which are accessible via the access panels in both cockpits, so it must be assumed that on some gliders these bearings have never been serviced.
2. The time between lubrications can be increased to 1 year due to service experience.
3. The securing ropes of the head rest in the rear cockpit must prevent the head-rest from interfering with the rear control stick when the head rest is moved to its most forward position.
4. Some manual corrections.

Instructions :

1. Remove the access panels (2 in the front and 2 in the rear cockpit): You have to remove the height adjustable seat pan from the rear cockpit first. Clean and grease all accessible bearings (ball bearings and rod ends with universal bearings). Reinstall access panels and seat pan.
2. Check the securing ropes of the head rest in the rear cockpit for wear and correct length. The securing ropes must prevent the head rest from interfering with the rear control stick when the head rest is moved to its most forward position.
3. Exchange the following manual pages against new pages issued January 2001 marked with TN 348/15.

Model	Flight manual	Maintenance manual
DG-500 Trainer	0.1, 0.3, 0.4, 4.5, 7.7, 8.2	1, 2, 24
DG-500 Orion	0.1, 0.3, 0.4, 4.7, 7.6, 8.2	1, 2, 25
DG-500/20	0.1, 0.3, 0.4, 4.7, 7.7, 8.2	1, 2, 9, 17, 26
DG-500/22	0.1, 0.3, 0.4, 4.7, 7.7, 8.2	1, 2, 9, 26

Material : Multi-purpose greases for rolling element bearings
Nylon or Perlon cord 3mm
Manual pages see instruction 3

Weight and balance : /

Remarks : All instructions may be executed by the owner. They have to be inspected and entered in the aircraft logs by a licensed inspector with the next annual inspection.

Bruchsal, date:
January 26, 2001

LBA - approved:

Author:
Dipl. Ing. Wilhelm Dirks

The German original of this TN has been approved by the LBA under the date of Feb. 7, 2001 and is signed by Mr. Feadt. The translation into English has been done by best knowledge and judgement.

W. Dirks
Type certification
inspector:
Dipl. Ing. Swen Lehner

Swen Lehner



**Airworthiness
Directive
2001-080**

Luffahrt-Bundesamt
Airworthiness Directive Section
Hermann-Blenk-Str. 26
38108 Braunschweig
Federal Republic of Germany

Effective Date: March 08, 2001

Glaser Dirks

Affected:

Kind of aeronautical product: Powered Sailplane
Manufacturer: DG-Flugzeugbau, Bruchsal, Germany
Type: DG-500M
Model: all
Serial numbers affected: all
German Type Certificate No.: 843

Subject/Reason:

Ball bearings and articulated rod ends in the cockpit area.
If lubrication tasks on the ball bearings and the articulated rod ends in the cockpit area are not performed properly, this may lead to rough operation or to jamming of the bearing/articulated rod connections.

Aft control stick
Damage to or incorrect length of the retaining cables of the aft head rest may cause blocking of the aft control stick.

Action:
Lubrication of the ball bearings and articulated rod ends located below the access panels in the cockpits as well as checks of the retaining cables of the aft head rest for proper condition and correct length in accordance with the specifications of the Technical Information.

We expressly point out that nos. 2, 4 and 5 of the manufacturer's Technical Information are not subject of this AD. The accomplishment of those items is to be considered a recommendation given by the manufacturer. The actions must be done in accordance with the Technical Note of the manufacturer.

Compliance:
Actions to be accomplished not later than March 31, 2001.

Technical publication of the manufacturer:
DG-Flugzeugbau Technical Note No. 843/16 dated January 26, 2001 which becomes herewith part of this AD and may be obtained from Messrs.:

DG-Flugzeugbau
Postbox 41 20
D- 76625 Bruchsal
Federal Republic of Germany
Phone: ++ 49 7257 890 Fax: ++ 49 7257 8922

Accomplishment and log book entry:
Action to be accomplished by an approved service station and to be checked and entered in the log book by a licensed inspector.

Holders of affected aircraft registered in Germany have to observe the following:
As a result of the a.m. deficiencies, the airworthiness of the aircraft is affected to such an extent that after the expiry of the a.m. dates the aircraft may be operated only after proper accomplishment of the prescribed actions. In the interest of aviation safety outweighing the interest of the receiver in a postponement of the prescribed actions, the immediate compliance with this AD is to be directed

Instructions about Available Legal Remedies:
An appeal to this notice may be raised within a period of one month following notification. Appeals must be submitted in writing or registered at the Luftfahrt-Bundesamt, Hermann-Blenk-Str. 26, 38108 Braunschweig.

Enquiries regarding this Airworthiness Directive should be referred to Mr. Olaf Schneider, Airworthiness Directive Section at the above address, fax-no. 0049 531/2355-720. Please note, that in case of any difficulty, reference should be made to the German issue!

DG Flugzeugbau GmbH
76646 Bruchsal

Technical Note
No. 843/16

Subject : Greasing schedule / manual revision
Effectivity : DG-500M all serial no., DG-500MB all serial no.
Accomplishment : 31.03.2001
Reason :

1. The greasing schedule in the maintenance manual does not point out the bearings which are accessible via the access panels in both cockpits, so it must be assumed that on some gliders these bearings have never been serviced.
2. The time between lubrications can be increased to 1 year due to service experience.
3. The securing ropes of the head rest in the rear cockpit must prevent the head-rest from interfering with the rear control stick when the head rest is moved to its most forward position.
4. On the DG-500MB the carburettor control lever was replaced by an improved lever from ser. no. 5E213 and on. This new lever can also be installed on earlier ser.nos. as an option.
5. Some manual corrections.

Instructions :

1. Remove the access panels (2 in the front and 2 in the rear cockpit): You have to remove the height adjustable seat pan from the rear cockpit first. Clean and grease all accessible bearings (ball bearings and rod ends with universal bearings). Reinstall access panels and seat pan.
2. Check the securing ropes of the head rest in the rear cockpit for wear and correct length. The securing ropes must prevent the head rest from interfering with the rear control stick when the head rest is moved to its most forward position.
3. Exchange the following manual pages against new pages issued January 2001 marked with TN 843/16:

Model	Flight manual	Maintenance manual
DG-500 M	0.1, 0.3, 0.5, 4.8, 7.14, 8.2	1, 2, 3, 11, 45, 63
DG-500 MB	0.1, 0.3, 4.8	1, 2, 3, 4, 11, 19, 27, 45, 47, 48, 49, 51, 54, 62, 71, 79, 91 wiring scheme 5E101 (issued 10.05.00), drawing W40 (issued 30.11.99)

Material : Multi-purpose greases for rolling element bearings
Nylon or Perlon cord 3mm
Manual pages see instruction 3

Weight and balance : /

Remarks : All instructions may be executed by the owner. They have to be inspected and entered in the aircraft logs by a licensed inspector with the next annual inspection.

Bruchsal, date:
January 26. 2001

LBA – approved:

Author:
Dipl. Ing. Wilhelm Dirks

Wilhelm Dirks

Type certification
inspector:
Dipl. Ing. Swen Lehner

Swen Lehner

The German original of this TN has been approved by the LBA under the date of Feb. 7. 2001 and is signed by Mr. Blume. The translation into English has been done by best knowledge and judgement.



British Gliding Association
Aircraft Inspection

Recommended

Number: 012/03/2001	Issue: 1
------------------------	-------------

Date: 9th March 2001

- 1NS 03/04/01
- 1.14
- Subject:** Fuselage – Bulkhead 13 Cracking
- Applicability:** LET L13 Blanik
- Accomplishment:** At C of A inspection or sooner if tow out gear using lift tube is regularly used.
- Reason:** Cracks in bulkhead 13 possibly induced by side movement when using aft lift tube to attach tow out gear.
- Instructions:** Inspect bulkhead 13 for cracks paying particular attention to the aluminium angles that form part of the bulkhead. If the bulkhead is found to be cracked the manufacturers recommend that it be replaced. LET advise that the new bulkhead is inexpensive at about \$20 for both parts. (P/No. L/H A102 008L, R/H A102 008P – check applicability) Parts Dept, (Czech Republic) Mrs. Latynova, Fax 00 420 632 564102.

Approved By
Jim Hammerton, Chief Technical Officer

Issued by - The British Gliding Association Ltd, Kimberley House, Vaughan Way, Leicester, LE1 4SE, U.K.

Note: Mandatory inspections must be recorded in the aircraft log book, unless specified, and certified by an appropriately rated BGA inspector. Optional inspections should be entered into the D.I. book or log book as appropriate. Optional inspections may be certified by a BGA Pilot instructor.



**Airworthiness
Directive
2001-110**

TNS 03/04/01 1.16
Luftfahrt-Bundesamt
Airworthiness Directive Section
Hermann-Blenk-Str. 26
38108 Braunschweig
Federal Republic of Germany

Rolladen-Schneider

Effective Date: April 05, 2001

Affected:

Kind of aeronautical product: Sailplane
Manufacturer: Rolladen-Schneider, Egelsbach, Germany
Type: LS 6
Models affected: only LS 6-c
Serial numbers affected: all
German Type Certificate No.: 357

Subject:

Extension of the service time and Supplements of the Maintenance Manual

Reason:

The results of fatigue tests (subsequently carried out on wing spar sections) have demonstrated that the time in service of GFRP sailplanes may be extended to 12000 hours, provided the airworthiness of each individual aircraft is evidenced by a special multi-stage inspection program, which is then to be incorporated into the Maintenance Manual.

Action:

Insert revisions of the Maintenance Manual and whenever one of the various limits in service time is reached, an inspection is to be performed according to an „Inspection program for extending the service time“ which may be obtained from the manufacturer.

The actions must be done in accordance with the Technical Notes of the manufacturer.

Compliance:

The action must be performed on reaching a service time of 3000 flight hours.

Technical publication of the manufacturer:

Rolladen-Schneider Technical Bulletin No. 6035 Edition 30. Oktober 2000 which becomes herewith part of this AD and may be obtained from Messrs.:

Rolladen-Schneider
Flugzeugbau GmbH
Mühlstrasse 10

D- 63329 Egelsbach
Federal Republic of Germany
Phone: ++ 49 6103 204126
Fax: ++ 49 6103 45526

Accomplishment and log book entry:

Action to be accomplished by an approved service station and to be checked and entered in the log book by a licensed inspector.

Holders of affected aircraft registered in Germany have to observe the following:

As a result of the a.m. deficiencies, the airworthiness of the aircraft is affected to such an extent that after the expiry of the a.m. dates the aircraft may be operated only after proper accomplishment of the prescribed actions. In the interest of aviation safety outweighing the interest of the receiver in a postponement of the prescribed actions, the immediate compliance with this AD is to be directed

Instructions about Available Legal Remedies:

An appeal to this notice may be raised within a period of one month following notification. Appeals must be submitted in writing or registered at the Luftfahrt-Bundesamt, Hermann-Blenk-Str. 26, 38108 Braunschweig.

Enquiries regarding this Airworthiness Directive should be referred to Mr. Olaf Schneider, Airworthiness Directive Section at the above address, fax-no. 0049 531/2355-720. Please note, that in case of any difficulty, reference should be made to the German issue!



TWS 03104101 1.17

**Airworthiness
Directive
1999-266/2**

Luftfahrt-Bundesamt
Airworthiness Directive Section
Hermann-Blenk-Str. 26
38108 Braunschweig
Federal Republic of Germany

Rolladen-Schneider

Effective Date: March 15, 2001

Affected:

Kind of aeronautical product: Sailplane
Manufacturer: Rolladen-Schneider, Egelsbach, Germany
Type: LS 6
Models affected: All
Serial numbers affected: All
Note:
Please consider notes in the Technical Bulletin
German Type Certificate No.: 357

Subject:

Obstruction of emergency canopy jettison and avoidance of possible injuries

Reason / Action:

A deflector on the upper instrument panel edge avoids possible jamming of the instrument panel between the canopy mounted panel cover after actuation of the canopy emergency jettison. Install an edge protector on the deflector, if not already has been done.

The actions must be done in accordance with the instructions given in the Technical Bulletin.

Compliance:

Before the next flight.

Technical publication of the manufacturer:

Rolladen-Schneider Technical Bulletin No. 6036/2 dated February 12, 2001 which becomes herewith part of this AD and may be obtained from Messrs.:

Rolladen-Schneider
Flugzeugbau GmbH
Mühlstrasse 10

D- 63329 Egelsbach
Federal Republic of Germany
Phone: ++ 49 6103 204126
Fax: ++ 49 6103 45526

Accomplishment and log book entry:

Action to be accomplished by an approved service station and to be checked and entered in the log book by a licensed inspector.

Note:

This AD supersedes the AD-No. 1999-266 dated July 06, 1999..

Holders of affected aircraft registered in Germany have to observe the following:

As a result of the a.m. deficiencies, the airworthiness of the aircraft is affected to such an extent that after the expiry of the a.m. dates the aircraft may be operated only after proper accomplishment of the prescribed actions. In the interest of aviation safety outweighing the interest of the receiver in a postponement of the prescribed actions, the immediate compliance with this AD is to be directed

Instructions about Available Legal Remedies:

An appeal to this notice may be raised within a period of one month following notification. Appeals must be submitted in writing or registered at the Luftfahrt-Bundesamt, Hermann-Blenk-Str. 26, 38108 Braunschweig.



**Airworthiness
Directive
1999-267/2**

TNS 03/04/01 1-18
Luftfahrt-Bundesamt
Airworthiness Directive Section
Hermann-Blenk-Str. 26
38108 Braunschweig
Federal Republic of Germany

Rolladen-Schneider

Effective Date: March 15, 2001

Affected:

Kind of aeronautical product: Sailplane
Manufacturer: Rolladen-Schneider, Egelsbach, Germany
Type: LS 7
Models affected: All
Serial numbers affected: All
Note:
Please consider notes in the Technical Bulletin
German Type Certificate No.: 375

Subject:

Obstruction of emergency canopy jettison and avoidance of possible injuries

Reason / Action:

A deflector on the upper instrument panel edge avoids possible jamming of the instrument panel between the canopy mounted panel cover after actuation of the canopy emergency jettison. Install an edge protector on the deflector, if not already has been done.

The actions must be done in accordance with the instructions given in the Technical Bulletin.

Compliance:

Before the next flight.

Technical publication of the manufacturer:

Rolladen-Schneider Technical Bulletin No. 7011/2 dated February 12, 2001 which becomes herewith part of this AD and may be obtained from Messrs.:

Rolladen-Schneider
Flugzeugbau GmbH
Mühlstrasse 10

D- 63329 Egelsbach
Federal Republic of Germany
Phone: ++ 49 6103 204126
Fax: ++ 49 6103 45526

Accomplishment and log book entry:

Action to be accomplished by an approved service station and to be checked and entered in the log book by a licensed inspector.

Note:

This AD supersedes the AD-No. 1999-267 dated July 06, 1999..

Holders of affected aircraft registered in Germany have to observe the following:

As a result of the a.m. deficiencies, the airworthiness of the aircraft is affected to such an extent that after the expiry of the a.m. dates the aircraft may be operated only after proper accomplishment of the prescribed actions. In the interest of aviation safety outweighing the interest of the receiver in a postponement of the prescribed actions, the immediate compliance with this AD is to be directed

Instructions about Available Legal Remedies:

An appeal to this notice may be raised within a period of one month following notification. Appeals must be submitted in writing or registered at the Luftfahrt-Bundesamt, Hermann-Blenk-Str. 26, 38108 Braunschweig.



**Airworthiness
Directive
1999-268/2**

TNS 03/04/01 1.19

Luftfahrt-Bundesamt
Airworthiness Directive Section
Hermann-Blenk-Str. 26
38108 Braunschweig
Federal Republic of Germany

Rolladen-Schneider

Effective Date: March 15, 2001

Affected:

Kind of aeronautical product: Sailplane
Manufacturer: Rolladen-Schneider, Egelsbach, Germany
Type: LS 8
Models affected: All
Serial numbers affected: All
Note:
Please consider notes in the Technical Bulletin
German Type Certificate No.: 402

Subject:

Obstruction of emergency canopy jettison and avoidance of possible injuries

Reason / Action:

A deflector on the upper instrument panel edge avoids possible jamming of the instrument panel between the canopy mounted panel cover after actuation of the canopy emergency jettison. Install an edge protector on the deflector, if not already has been done.

The actions must be done in accordance with the instructions given in the Technical Bulletin.

Compliance:

Before the next flight.

Technical publication of the manufacturer:

Rolladen-Schneider Technical Bulletin No. 8004/2 dated February 12, 2001 which becomes herewith part of this AD and may be obtained from Messrs.:

Rolladen-Schneider
Flugzeugbau GmbH
Mühlstrasse 10

D- 63329 Egelsbach
Federal Republic of Germany
Phone: ++ 49 6103 204126
Fax: ++ 49 6103 45526

Accomplishment and log book entry:

Action to be accomplished by an approved service station and to be checked and entered in the log book by a licensed inspector.

Note:

This AD supersedes the AD-No. 1999-268 dated July 06, 1999.

Holders of affected aircraft registered in Germany have to observe the following:

As a result of the a.m. deficiencies, the airworthiness of the aircraft is affected to such an extent that after the expiry of the a.m. dates the aircraft may be operated only after proper accomplishment of the prescribed actions. In the interest of aviation safety outweighing the interest of the receiver in a postponement of the prescribed actions, the immediate compliance with this AD is to be directed

Instructions about Available Legal Remedies:

An appeal to this notice may be raised within a period of one month following notification. Appeals must be submitted in writing or registered at the Luftfahrt-Bundesamt, Hermann-Blenk-Str. 26, 38108 Braunschweig.

TNS 03/04/01 1.26



British Gliding Association Aircraft Inspection

Mandatory

Number: 013/03/2001	Issue: 1
------------------------	-------------

Date: 12th March 2001

- Subject:** Flying Controls – Elevator Disconnection and Tailplane Attachment
- Applicability:** Slingsby T65 Vega Sailplanes
- Accomplishment:** 25 Flying Hours or 10 landings from issue date and subsequent Annual inspections
- Reason:** In flight failure of elevator control tongue causing flutter and uncontrolled elevator movement. Tailplane retaining pin mountings in top of fin cracked. Both conditions possibly caused by elevator rocking beam actuator acting on incorrect point. (1" forward of pivot point and not on Pad, witnessed by cuts in top of control tongue)
- The Elevator control system and Tailplane retention continues to be a problem area and the cause of in-flight failures. The following measures are intended to highlight problems and ensure continued airworthiness.
- Instructions:**
- 1/ Check for correct incorporation of TI104/T65. Pay particular attention to the reinforcement of the elevator control tongue. Check for disbonding of the reinforcement.
 - 2/ Carry out inspection items detailed in TI104/T65 1.1 & 1.2. 1.3 is not possible due to the reinforcement, but inspect the general area.
 - 3/ Check for adequate clearance of the rocking beam actuator in the elevator control tongue. Ensure that the top of the beam is clear of the tongue. Look for actuator cutting into tongue.
 - 4/ Check the elevator drive pads are in contact for both "up" and "down" control. (Either by witness marks or the use of a small piece of soft plasticine)
 - 5/ Carry out a close visual examination of the Tailplane retaining pin mountings located on the top of the fin for cracks.
 - 6/ Ensure compliance with all annual inspection items as detailed in BGA 2001 Compendium
 - 7/ A copy of TI104/T65 is attached.

Approved By
Jim Hammerton, Chief Technical Officer

Issued by - The British Gliding Association Ltd, Kimberley House, Vaughan Way, Leicester, LE1 4SE, U.K.

Note: Mandatory inspections must be recorded in the aircraft log book, unless specified, and certified by an appropriately rated BGA inspector. Optional inspections should be entered into the D.I. book or log book as appropriate. Optional inspections may be certified by a BGA Pilot instructor.

SLINGSBY ENGINEERING LIMITED

AIRCRAFT DIVISION

TECHNICAL INSTRUCTION

TITLE	T65 'VEGA' Central Elevator Hinge on Tailplane, Elevator Tongue & Pivot Bearings for Elevator Rocker Arm.	T.I. No. 104/T65 Iss.2
CLASSIFICATION	C.A.A. Mandatory	
COMPLIANCE	Inspection to be carried out before the next flight unless LTO 'Elevator & Canopy Jettison Mechanism', 20th August has been carried out.	
OBJECTIVE	To ensure structural integrity of the central elevator hinge on tailplane elevator drive tongue and to inspect the pivot bearings for the elevator rocker arm assy. Also to reinforce central elevator hinge on tailplane.	
JUSTIFICATION	Cracking and a lack of stiffness has occurred in the area 'A' (Fig 1), the cause of which is attributable to heavy landings and/or excessive bearing loads during elevator assembly.	
APPLICABILITY	All Slingsby T65A, C, D gliders, including spare tailplane/elevators expanding on CAA Airworthiness Directive No.008-08-82. (LTO 'Elevator & Canopy Jettison Mechanism', 20th August).	
CONSEQUENTIAL LIMITATIONS	If cracking is found on the tailplane central hinge the repair will require a new central tailplane rib (T65A-30-15) which must be fitted by S.A.L. or an approved repair shop before next flight.	
ACTION	- Inspection to be carried out as follows :	
1.1	With the tailplane/elevator assembly removed from the aircraft examine the glass reinforced plastic operating tongue of the elevator which projects forwards into the tailplane. The lips of this channel shaped tongue must be unbroken and continuous to the point where it merges with the elevator proper. Check the tongue for lack of stiffness in the vertical sense by attempting to bend the tongue with the fingers. If any degree of cracking, damage or abnormal flexibility is found it must be rectified before further flight in accordance with a repair detailed in Section 2.	
	The preceding action must be carried out following a heavy landing or ground loop in addition to any other required inspections.	
1.2	Inspect the pivot bearings (04 DU 04) for the elevator rocker arm assembly, on the top of the fin for wear. Any wear found in excess of 0.01" in the fwd & aft direction must be rectified before further flight. Fitting of the bearing is detailed in Section 3.	
1.3	Inspect the tailplane centre hinge pin mounting rib at the section just forward of the hinge pin as detailed in Fig 6. If cracks or damage are found a repair entailing the fitting of a new 'reinforced' rib will be required. The repair scheme is detailed in Section 4 and should be undertaken by S.A.L. or an approved repair shop. If the section does not show signs of cracking a reinforcement cloth will be required as detailed in Section 5. Alternative means of repair for minor cracking may be carried out with the agreement of SAL.	
	Note - Use Epikote 162/Epikure 113 resin system throughout.	
ISSUED BY:	<i>B. Miller</i>	Date 22nd Sept 82
for and on behalf of	SLINGSBY ENGINEERING LIMITED Kirkbymoorside, York YO6 6EZ, England. Tel. 0751 31751 Telex 57911	Page 1 of 7

SLINGSBY ENGINEERING LIMITED

AIRCRAFT DIVISION

TECHNICAL INSTRUCTION

TITLE	T65 'VEGA' Central Elevator Hinge & Pivot Bearings For Elevator Rocker Arm.	T.I. No. 104/T65 Issue 2
	- (2) -	
2.1	Rectification of lack of stiffness of the elevator tongue will be as follows :-	
(a)	Remove the tailplane/elevator assembly from the aircraft.	
(b)	With the elevator removed from the tailplane, abrade the tongue of the elevator over the area detailed in Fig 2.	
(c)	Layup 2 layers of woven roving cloth (2 x 92125XX) over the area detailed in Fig 2.	
3.1	If the pivot bearing 04 DU 04 is worn it may be replaced as follows (refer Fig 3).	
(a)	Remove the tailplane/elevator assembly from the aircraft.	
(b)	Remove the split pin (Item 1) and washer from the central hinge of the actuator (located on top of fin).	
(c)	Remove pin (Item 2).	
(d)	Disconnect the pushrod on the fwd end of the actuator (similar to above).	
(e)	Drift the bush from the elevator actuator assembly and replace with new bush (04 DU 04), available from S.A.L.	
(f)	New split pins must be fitted when reassembling.	
4.1	Replacement of the central tailplane rib with reinforced rib only available from S.A.L. will be carried out as follows (Refer Fig 4).	
(a)	Remove the tailplane/elevator assembly from the aircraft.	
(b)	Cut away the central part of the rib taking care not to damage the skin or the main spar.	
(c)	Grind the remainder of the rib with a rotary file, again using extreme caution so as not to damage the skin or main spar.	
(d)	Abrade all surfaces where the rib is to be positioned.	
(e)	Coat the rib with glassflock and initially position the rib to the dimensions detailed in Fig 4.	
(f)	Position the tailplane in trestles as shown in Fig 5.	
ISSUED BY:	<i>B. Miller</i>	Date 14th Sept 82
for and on behalf of	SLINGSBY ENGINEERING LIMITED Kirkbymoorside, York YO6 6EZ, England. Tel. 0751 31751 Telex 57911	Page 2 of 7

Cont'd ...

TECHNICAL INSTRUCTION

TITLE T65 'VEGA' Central Elevator Hinge & Pivot Bearings For Elevator Rocker Arm. T.I. No. 104/T65 Issue 2

(3) -

- 4.1 (g) Fit the elevators checking the split pin hole is accessible. The rib should now be correctly positioned.
- (h) Carefully remove the elevators and apply the cleat cloths as detailed in Fig 4.
- (i) The elevators should now be repositioned to ensure the rib is still located in the correct position. The elevators should be pushed fully home again ensuring the split pin hole is accessible. Position wedges as shown in Fig 5 to hold the elevators in the neutral position.
- (j) When fitting the tailplane elevator assembly ensure the elevator tongue seats correctly on the actuator. If there is a clearance between the tongue and actuator the tongue must be built up in the Area 'B' detailed in Fig 2. If there is a foul between the tongue and actuator, the tongue must be trimmed (refer Area 'B' Fig 2) to seat properly on the actuator. Build up the cloth under the flanges and around the web to compensate for any cloth removed.
- (k) Cure for 8 hours at 56°C.
- 5.1 If the central elevator hinge on the tailplane is not cracked, reinforcement will be added as follows :-
- (a) Remove the tailplane/elevator assembly from the aircraft.
- (b) When the elevator is removed from the tailplane, lightly abrade the area shown in Fig 6.
- (c) Wrap a 10mm strip of 92110 # woven roving cloth 6 times around the area detailed.
- (d) When cured trim any rough edges.
- (e) Trim the elevator cutout to enable maximum deflection of the elevator
+24° ± 1° 30'
-16.5°
- (Note - the cutout may now be visible when full deflection of the elevator is applied.)
- (f) Cure for 8 hours at 56°C.

FIG 1 Area of Cracking on Vega T-Plane

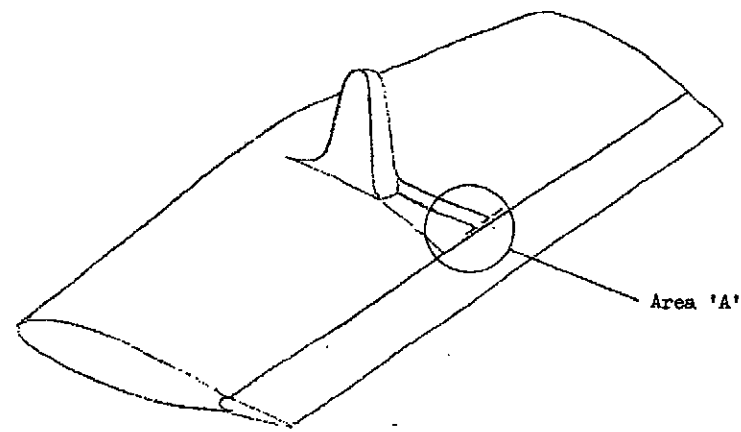
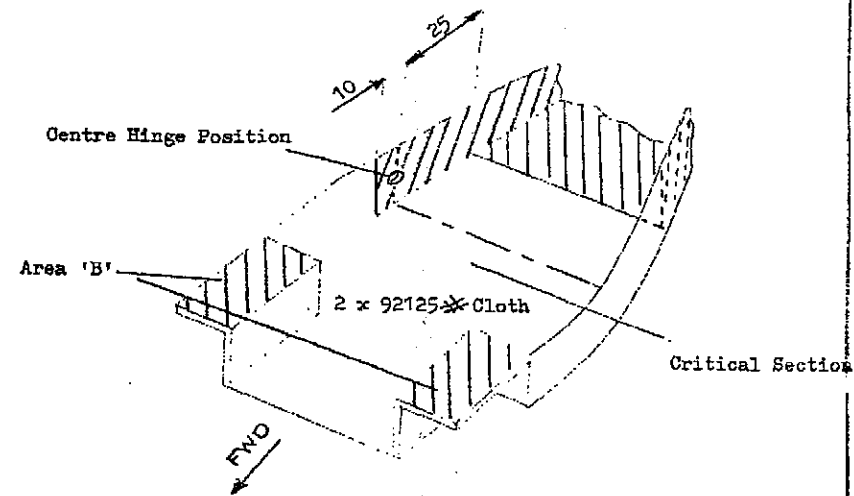

FIG 2 Reinforcement of Elevator-Tongue



Only layup cloth on the inside of the tongue on the area NOT shaded.

ISSUED BY: *B. Mellors*
for and on behalf of SLINGSBY ENGINEERING LIMITED
Kirkbymoorside, York YO6 6EZ, England, Tel 0751 31751 Telex 57911
Date 14th Sept 82
Page 3 of 7

RM

Slingsby Engineering Ltd.
 Technical Instruction
 104/T65

FIG 3 Actuator Pivot Bearing

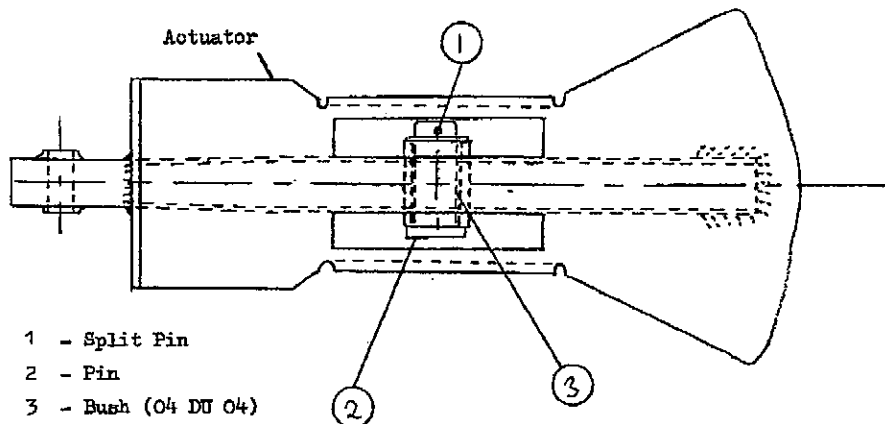

- 1 - Split Pin
- 2 - Pin
- 3 - Bush (O4 DU O4)

FIG 4 View of Central Section of T.Plane with the top skin removed.

Use Epikote 162 Epicure 113
 Resin System.

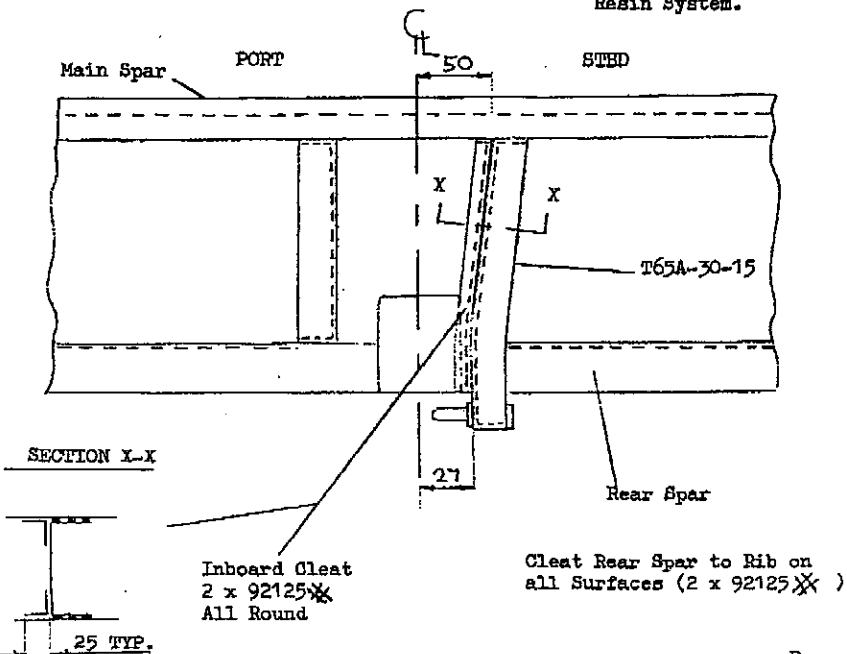

Slingsby Engineering Ltd.
 Technical Instruction
 104/T65

FIG 5 Positioning of Elevators

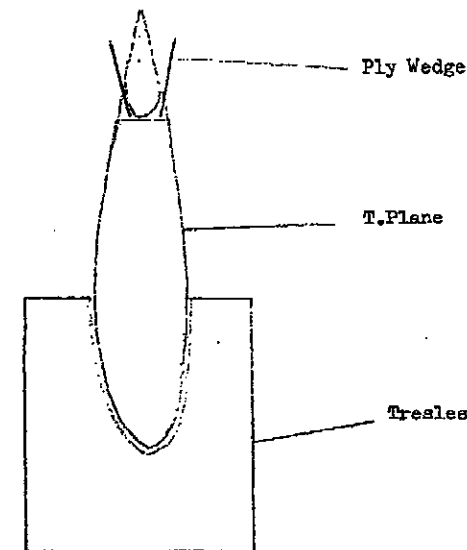
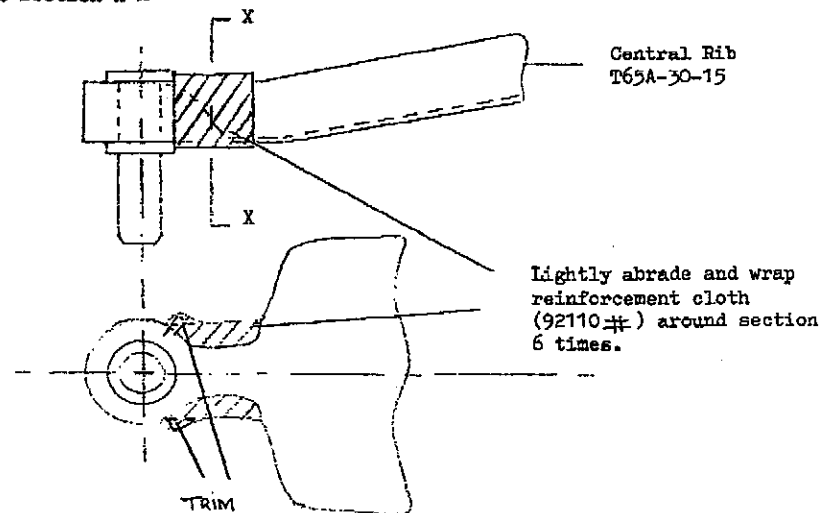

FIG 6 Reinforcement Cloth on the Centre Tailplane Hinge

Inspect Section X-X





TECHNICAL INSTRUCTION

TITLE T65 'VEGA' Central Elevator Hinge on Tailplane, Elevator Tongue & Pivot Bearings for Elevator Rocker Arm.	T.I. No. 104/T65 Issue 2
CLASSIFICATION CAA Mandatory	
COMPLIANCE The inspections described in Issue 1 should have been carried out on all gliders before next flight. Action resulting from 1.1, 1.2 and 1.3 also before next flight. Action from 5.1 page 3 must be carried out within 3 months of receipt of this T.I. at Issue 2.	
ACTION After carrying out repairs, log compliance with T.I. 104/T65 in glider log. Alter page 1 of Issue 1 to read Issue 2 and page 1 of 7. Attach this page to back of T.I.	
ISSUED BY: <i>B. Mellers</i> for and on behalf of SLINGSBY AVIATION <i>Kekbymoorside, York YO6 6EZ, England. Tel. 0751 31751 Telex 57911</i>	Date 14 February 1983 Page 7 of 7



Airworthiness
Directive
1999-224/5

Luftfahrt-Bundesamt
Airworthiness Directive Section
Hermann-Blenk-Str. 26
38108 Braunschweig
Federal Republic of Germany

Stemme GmbH & Co. KG
Flugplatzstraße 2, Nr. 7
D-15344 Strausberg
Federal Republic of Germany

Effective Date: March 22, 2001

Stemme

Affected:

Kind of aeronautical product:	Powered Sailplanes
Manufacturer:	Stemme, Berlin, Germany
Type:	Stemme S 10
Models affected:	Stemme S 10-V and ~VT
Serial numbers affected:	S10-V: 14-001 up to 14-030 and 14-012M up to 14-063M S10-VT: 11-001 up to 11-037
German Type Certificate No.:	846

Subject:

Variable Pitch Propeller – Propeller fork 10AP-V08 of propellers 10AP-V and 11AP-V / Project-No. 14-006

Reason:

Loss of one propeller blade including propeller fork during flight operation due to a fracture of the propeller fork at the end of its threaded fastening pin.

That fracture of the propeller fork may be caused by the stress which occurred during a ground contact of the propeller or a similar incident such as impact stop.

Putting out of operation of the propeller forks P/N 10AP-V08 on the occasion of the conversion of the propellers 10AP-V and 11AP-V to the design with the new forks P/N 10AP-V88.

Action:

The propellers 10AP-V and 11AP-V must be converted to the design with the new forks P/N 10AP-V88 (for both propellers).
Modification of the gearbox suspensions of the propeller 10AP-V and spacer tubes of the gearbox suspensions.
Perform an extra dynamic propeller balancing.

Note:

With publication of this Airworthiness Directive the requirement for revision of the appropriate service manual mentioned concerning the permissible operating times under the item 7 "Associated Documents" is no longer required.

The Technical Bulletin No. A31-10-001 as amended and approved by the LBA is to be applied.

Compliance:

The actions must be done before the next flight, if not already has been done.

Note:

For the purpose of the accomplishment of this AD one (1) ferry flight will be permitted; for this ferry flight the following conditions have to be met:

1. Proper condition and unrestricted functioning of the components concerned.
2. The ferry flight may be conducted only under visual flight conditions and with the minimum flight crew required for this flight.
3. Passengers, company staff members not required to conduct the flight and goods may not be carried.
4. The aircraft may not be flown over congested areas and assemblies of persons.
5. Prior to the flight, the pilot is to be informed about this exemption.
6. The conduct of the ferry flight is to be reported in writing to the Luftfahrt-Bundesamt stating a) the name of the pilot, b) the date of the flight, c) the time of departure and arrival and the AD number.

Technical publication of the manufacturer:

Stemme Service Bulletin No. A 31-10-051, Amendment-Index 05.c dated December 15, 1999 which becomes herewith part of this AD and may be obtained from Messrs.

Enquiries regarding this Airworthiness Directive should be referred to Mr. Olaf Schneider, Airworthiness Directive Section at the above address, fax-no. 0049 531/2355-720. Please note, that in case of any difficulty, reference should be made to the German issue!

Accomplishment and log book entry:

Action to be accomplished by an approved service station and to be checked and entered in the log book by a licensed inspector.

Note:

This AD supersedes the AD-No. 1999-224/4 dated December 10, 1999.

Holders of affected aircraft registered in Germany have to observe the following:

As a result of the a.m. deficiencies, the airworthiness of the aircraft is affected to such an extent that after the expiry of the a.m. dates the aircraft may be operated only after proper accomplishment of the prescribed actions. In the interest of aviation safety outweighing the interest of the receiver in a postponement of the prescribed actions, the immediate compliance with this AD is to be directed.

Instructions about Available Legal Remedies:

An appeal to this notice may be raised within a period of one month following notification. Appeals must be submitted in writing or registered at the Luftfahrt-Bundesamt, Hermann-Blenk-Str. 26, 38108 Braunschweig.



British Gliding Association Aircraft Inspection

Mandatory

Number: 014/03/2001	Issue: 1
------------------------	-------------

Date: 19th March 2001

- Subject: Flying Controls – Rudder pedal Adjustment
- Applicability: SZD Junior (SZD 51-1)
- Accomplishment: Within 10 flights and at each C of A annual inspection.
- Reason: Rudder pedal adjustment failed to properly lock causing rudder pedals to slide forward out of reach of pilot. The locking pin rode out of the adjustment hole by a combination of dished locating hole in fore and aft tube and short pin. The fore and aft tube is only 0.7 mm wall thickness and is easily damaged.
- Instructions: 1/ Inspect the fore and aft rudder pedal adjustment tube for dishing, wear or damage around the adjustment locating pin holes.
2/ Ensure the adjustment location pin engages on its full diameter by a minimum of 3mm inside the tube. This engagement is beyond any slight dishing of the fore and aft tube and the chamfer on the end of the pin.
Note: If the full engagement cannot be accomplished the aircraft must not be flown until after rectification.
- A modification is in the process of being developed to eliminate this problem.

Approved By
Jim Hammerton, Chief Technical Officer

Issued by - The British Gliding Association Ltd, Kimberley House, Vaughan Way, Leicester, LE1 4SE, U.K.

Note: Mandatory inspections must be recorded in the aircraft log book, unless specified, and certified by an appropriately rated BGA inspector. Optional inspections should be entered into the D.I. book or log book as appropriate. Optional inspections may be certified by a BGA Pilot instructor.

TWS 03/04/01 1-28



British Gliding Association
Aircraft Inspection

Number: 015/04/2001	Issue: 1
------------------------	-------------

Mandatory

Date: 20th April 2001

- Subject:** Air Brake System – Failure of bevel drive gears.
- Applicability:** SZD 51-1 Junior.
- Accomplishment:** Part 1 – Within 10 flight hours and at each annual C of A inspection.
Part 2 – At each Pre Flight (DI) inspection – optional.
- Reason:** The failure of one of the airbrake mechanism bevel gears will cause asymmetric deployment of the airbrakes, there is a possibility that this may have contributed to a recent accident.
- Instructions:** Part 1.
1/ De-rig aircraft.
2/ Locate air brake bevel gears in wing root and ensure they are clean, remove excessive grease as far as possible.
3/ Using an endoscope or magnifying mirror, strong light or other suitable inspection equipment inspect both bevel gears over entire visible surface and meshed area for cracks, splits, distortion, surface pits or blow holes. Slowly actuate airbrake during inspection. Pay particular attention to the root area of each tooth and the area surrounding the retention ring nut.
4/ Inspect the face of the meshing teeth for signs of foreign object damage (FOD)
Note: This inspection is difficult, as the access is poor.
5/ If any damage is found or suspected the gears must be removed from the wing and dismantled from the drive shafts for a close inspection prior to further flight. It should be possible to remove the air brake gear carrier assembly through the access hole in the wing root after removal of the aileron control bellcranks and bracket. The mounting nuts are staked; it is permissible to replace them with suitable self-locking nuts.
6/ **The aircraft is grounded if defects are present.**

Continued on next page,

Issued by - The British Gliding Association Ltd, Kimberley House, Vaughan Way, Leicester, LE1 4SE, U.K.
Note: Mandatory inspections must be recorded in the aircraft log book, unless specified, and certified by an appropriately rated BGA inspector.
Optional inspections should be entered into the D.I. book or log book as appropriate. Optional inspections may be certified by a BGA Pilot.

015/04/2001 Issue 1, Page 2

- 6/cont. Please inform the BGA immediately of any defects found as this may have implications for the depth of inspection required on the other aircraft. (Please use BGA 1022 Engineering Occurrence form if possible)
7/ Defective gears must be replaced before further flight.
8/ Record compliance with this inspection in the Glider log book.

Part 2 – Optional inspection.

To be carried out at each pre flight (DI) inspection and may be certified as part of the daily inspection by a qualified pilot.

- 1/ Pay special attention to the operation of the air brake system.
- 2/ Check for smooth even operation, lumpiness, stiff spots and excessive over centre lock forces.
- 3/ Any abnormality found must be investigated before flight.

Approved By
Jim Hammerton, Chief Technical Officer

1.30
1 NS 03/04/01



British Gliding Association Aircraft Inspection

Mandatory

Number: 016/04/2001	Issue: 1
------------------------	-------------

Date: 20th April 2001

- Subject:** Air Brake System – Failure of bevel drive gears.
- Applicability:** SZD 50-1 & 50-3 Puchacz
- Accomplishment:** Part 1 – Within 10 flight hours and at each annual C of A inspection.
Part 2 – At each Pre Flight (DI) inspection – optional.
- Reason:** The failure of one of the airbrake mechanism bevel gears will cause asymmetric deployment of the airbrakes, there is a possibility that this may have contributed to a recent accident.
- Instructions:** Part 1.
1/ De-rig aircraft.
2/ Locate air brake bevel gears in wing root and ensure they are clean, remove excessive grease as far as possible.
3/ Using an endoscope or magnifying mirror, strong light or other suitable inspection equipment inspect both bevel gears over entire visible surface and meshed area for cracks, splits, distortion, surface pits or blow holes. Slowly actuate airbrake during inspection. Pay particular attention to the root area of each tooth and the area surrounding the retention ring nut.
4/ Inspect the face of the meshing teeth for signs of foreign object damage (FOD)
Note: This inspection is very difficult, as the access is poor through the small hole in the wing rib.
5/ If any damage is found or suspected the gears must be removed from the wing and dismantled from the drive shafts for a close inspection prior to further flight. The removal of the gears will entail an access hole being cut in the wing skin. The mounting for the gears is bonded to the wing structure.
6/ **The aircraft is grounded if defects are present.**

Continued on next page,

Issued by - The British Gliding Association Ltd, Kimberley House, Vaughan Way, Leicester, LE1 4SE, U.K.
Note: Mandatory inspections must be recorded in the aircraft log book, unless specified, and certified by an appropriately rated BGA inspector.
Optional inspections should be entered into the D.I. book or log book as appropriate. Optional inspections may be certified by a BGA Pilot.

016/04/2001 Issue 1, Page 2

- 6/cont. Please inform the BGA immediately of any defects found as this may have implications for the depth of inspection required on the other aircraft. (Please use BGA 1022 Engineering Occurrence form if possible)
- 7/ Defective gears must be replaced before further flight.
- 8/ Record compliance with this inspection in the Glider log book.

Part 2 – Optional Inspection.
To be carried out at each pre flight (DI) inspection and may be certified as part of the daily inspection by a qualified pilot.

- 1/ Pay special attention to the operation of the air brake system.
2/ Check for smooth even operation, lumpiness, stiff spots and excessive over centre lock forces.
3/ Any abnormality found must be investigated before flight.

Approved By
Jim Hammerton, Chief Technical Officer



British Gliding Association
Aircraft Inspection

Number: 017/04/2001	Issue: 1
------------------------	-------------

Mandatory

Date: 27th April 2001

- Subject:** Air Brake System – Failure of bevel drive gears.
- Applicability:** All SZD Aircraft incorporating Nylon Airbrake bevel gears located in the wing root.
(This Inspection does NOT apply to SZD 50-1 & 3 Puchacz or SZD 51-1 Junior, specific inspections apply)
- Accomplishment:** Part 1 – Within 10 flight hours and at each annual C of A inspection.
Part 2 – At each Pre Flight (DI) inspection – optional.
- Reason:** The failure of one of the airbrake mechanism bevel gears will cause asymmetric deployment of the airbrakes, there is a possibility that this may have contributed to a recent accident.
- Instructions:** Part 1.
1/ De-rig aircraft.
2/ Locate air brake bevel gears in wing root and ensure they are clean, remove excessive grease as far as possible.
3/ Using an endoscope or magnifying mirror, strong light or other suitable inspection equipment inspect both bevel gears over entire visible surface and meshed area for cracks, splits, distortion, surface pits or blow holes. Slowly actuate airbrake during inspection. Pay particular attention to the root area of each tooth and the area surrounding the retention ring nut.
4/ Inspect the face of the meshing teeth for signs of foreign object damage (FOD)
Note: Due to the wide variation of aircraft, the complexity of this inspection is not known. Persons carrying out this inspection should make an assessment as to the most satisfactory means of access with cutting holes as an absolute last resort. Should cutting an access hole be required the inspection should be entrusted to a competent GRP workshop so that the necessary reinforcement be reinstated. If possible leave the inspection hole open for future inspections.

Continued on next page,

Issued by - The British Gliding Association Ltd, Kimberley House, Vaughan Way, Leicester, LE1 4SE, U.K.
Note: Mandatory inspections must be recorded in the aircraft log book, unless specified, and certified by an appropriately rated BGA inspector.
Optional inspections should be entered into the D.I. book or log book as appropriate. Optional inspections may be certified by a BGA Pilot.

017/04/2001 Issue 1, Page 2

- 5/ If any damage is found or suspected the gears must be removed from the wing and dismantled from the drive shafts for a close inspection prior to further flight.
6/ **The aircraft is grounded if defects are present.**
Please inform the BGA immediately of any defects found as this may have implications for the depth of inspection required on the other aircraft. (Please use BGA 1022 Engineering Occurrence form if possible)
7/ Defective gears must be replaced before further flight.
8/ Record compliance with this inspection in the Glider log book.

Part 2 – Optional inspection.

To be carried out at each pre flight (DI) inspection and may be certified as part of the daily inspection by a qualified pilot.

- 1/ Pay special attention to the operation of the air brake system.
2/ Check for smooth even operation, lumpiness, stiff spots and excessive over centre lock forces.
3/ Any abnormality found must be investigated before flight.

Approved By
Jim Hammerton, Chief Technical Officer

Issued by - The British Gliding Association Ltd, Kimberley House, Vaughan Way, Leicester, LE1 4SE, U.K.
Note: Mandatory inspections must be recorded in the aircraft log book, unless specified, and certified by an appropriately rated BGA inspector.
Optional inspections should be entered into the D.I. book or log book as appropriate. Optional inspections may be certified by a BGA Pilot.



**Airworthiness
Directive
2001-089**

Luftfahrt-Bundesamt
Airworthiness Directive Section
Hermann-Blenk-Str. 26
38108 Braunschweig
Federal Republic of Germany

Effective Date: February 23, 2001

Valentin Flugzeugbau

Affected:

Kind of aeronautical product: Sailplane
Manufacturer: Valentin Flugzeugbau, Germany
Type: mistral-c
Models affected: mistral-c
Serial numbers affected: all
German Type Certificate No.: 329

Subject:

Ailerons - Residual momentum of ailerons

Reason:

Recently inspections have shown, that the residual momentum of the ailerons are not in their normal limits.

Action:

Measure the residual momentum of the ailerons according with the instructions given in the Maintenance Manual. If the momentum of the ailerons are not in limit, perform a repair in accordance with the instructions given in the Operational Instructions.

Compliance:

Before the next flight.

Technical publication:

Eichelsdörfer Technical Note No. 329-013 dated February 08, 2001 which becomes herewith part of this AD can be obtained from Messrs.:

Eichelsdörfer GmbH
Hafenstr. 6

D-96052 Bamberg
Federal Republik of Germany

Phone: ++ 49 951 61413
Fax: ++ 49 951 67772

Accomplishment and log book entry:

Action to be accomplished by the owner of the aircraft or an approved service station and to be checked and entered in the log book by a licensed inspector.

Holders of affected aircraft registered in Germany have to observe the following:

As a result of the a.m. deficiencies, the airworthiness of the aircraft is affected to such an extent that after the expiry of the a.m. dates the aircraft may be operated only after proper accomplishment of the prescribed actions. In the interest of aviation safety outweighing the interest of the receiver in a postponement of the prescribed actions, the immediate compliance with this AD is to be directed.

Instructions about Available Legal Remedies:

An appeal to this notice may be raised within a period of one month following notification. Appeals must be submitted in writing or registered at the Luftfahrt-Bundesamt, Hermann-Blenk-Str. 26, 38108 Braunschweig.

Enquiries regarding this Airworthiness Directive should be referred to Mr. Olaf Schneider, Airworthiness Directive Section at the above address, fax-no. 0049 531/2355-720. Please note, that in case of any difficulty, reference should be made to the German issue!

British Gliding Association

Minor Modification Application – Glider/SSMG.

[For CAA Reg.(G-) aircraft use CAA form AD261]



BGA Mod No.
BGA 2001/16
BGA USE ONLY

Aircraft Type ASK 13 & 18	Name & Address of applicant BGA General Issue	Applicants Mod Number BGA 2001/16
Reg. No. BGA		Issue No 1
Serial No All S/Nos.	Tel.	Date 25th April 2001

Details of Modification (use continuation sheets if necessary)

BGA Mandatory inspection 010/12/2000 issue 1 requires the dimensions between the elevator control linkage be checked and corrected if out of limits in accordance with Schleicher Drawing "Automatic Elevator Connection"

To assist in achieving the "b2" dimension it is permissible to introduce a spacer of up to 6mm between the fwd fin plate and the swinging link bracket in accordance with the following:

- 1/ The spacer is manufactured from Aircraft grade plywood and Maximum 6mm thick.
- 2/ The spacer is glued to the fwd fin plate using approved wood adhesive.
- 3/ Adequate surface protection is applied.
- 4/ The bracket mounting bolts are inspected and checked for length and replaced if nut safety cannot be achieved.
- 5/ It is permissible to angle the bracket up or down to achieve the "Ball bearing" centreline limits by a maximum of 2mm between mount bolts.
- 6/ Record the modification in the glider log book.

The justification for this modification: It has been found that over the years the position of the fin has altered through the possibility of many repairs due to the normal nature and use of these training aircraft.

Note:
To assist in achieving the dimensions quoted by Schleicher, un-drilled elevator control arms and fin brackets made to order are available. Contact the UK agent.

Suitable for installation on this aircraft only * Suitable for installation on any other <u>ASK 13 & 18</u>		Limitations, Conditions, Exemptions None.	
Weight & C of G Schedule. N/A	Flight Manual Amendment. N/A	Maintenance Manual Amendment. N/A	Electrical Load Analysis. N/A
Modification Instructions. Yes	Modification Drawings. None	Parts list. None	Published in TNS. 03/04/01

Can this modification be passed on to interested members within the BGA? Yes / No
Or. All enquires to be directed to originator. (The former will apply if no preference is shown)

The above modification has been approved for incorporation on BGA registered Aircraft only.

Signed [Signature] For BGA Date 25/4/01

* Delete as reqd, # Tick or N/A in box as reqd, BGA Use only.



7NS 03104-101 3.3
The British Gliding Association Ltd.
Registered No. 422605 England
Registered Office as address

Secretary: Barry Rolfe

Kimberley House, Vaughan Way,
Leicester LE1 4SE
Telephone 0116 2531051
Facsimile 0116 2515939
E-mail bga@gliding.co.uk

British Gliding Association

BGA Airworthiness Charges

Effective 1st May 2001

Glider C of A Issue or Renewal	£ 50.00
BGA Inspector Issue or Renewal	£ 21.00
Replacement of Lost BGA C of A	£ 15.00
Motor Glider and Tugs (G- reg.)	
3 year C of A by max weight:	
Up to 500 kg	£ 189.00
501 to 1000 kg	£ 378.00
1001 to 1500 kg	£ 567.00

Payable to the BGA.

Motor Glider and Tug charges as per Airworthiness Notice 25 issue 27.

Patron
Vice Presidents

The Duke of Edinburgh KG
Christopher R Simpson MA LLM
Roger Q Barrett
Tom Zealley BA PhD
Ben Watson MA FCA
Bill Walker OBE
Air Vice Marshal Don Spottiswood CB
Dick Dixon FCCII
Peter Hearne FREng MSc FRAeS



The British Gliding Association Ltd.
Registered No. 422605 England
Registered Office as address

Secretary: Barry Rolfe

Kimberley House, Vaughan Way,
Leicester LE1 4SE
Telephone 0116 2531051
Facsimile 0116 2515939
E-mail bga@gliding.co.uk

British Gliding Association

IMPORTANT NOTICE

CHANGES IN MOTOR GLIDER AND TUG CAA (G-REG) C of A PROCEDURES

NEW C of A ISSUES

For new or used aircraft requiring a UK CAA C of A first issue. Prototype and series aircraft. All applications should be made directly to the CAA and the BGA will have no involvement. All charges are payable to the CAA. The CAA procedure will be published as soon as finalised, in the interim please contact the CTO for the latest position

The CAA have decided that they wish "First Sight" of all aircraft that hold a CAA C of A and to avoid the delays by using a third party (BGA) to resolve any queries.

C of A RENEWAL (Using BGA M3 Approval DAI/8378/73 for the renewal of BGA aircraft C of A's in the Private category)

Application must be made to the BGA using CAA Form AD200 at least one month prior to renewing the C of A and remitting the current fee payable to the BGA. Complete the Applicant section with the name and address of the person who should be contacted regarding the renewal. An example AD200 and a spare form included in TNS 03/04/01.

On receipt the BGA will process and forward to the CAA.

The CAA will forward to the applicant a Flight Manual Amendment Status Report (FMAS) and Radio Installation Check sheet. (AD968)

On completion of the maintenance and flight test, forward a completed AD202NR, the completed FMAS, AD968 and flight test BGA 267FT. (CAA flight test schedule for Tug aircraft).

If the flight manual or radio is not at the standard indicated by the CAA records **DO NOT** hold up the application for C of A renewal but indicate the measures taken to resolve the discrepancies.

On receipt the BGA will process and forward the completed application to the CAA as normal.

The CAA will process the application in the normal way.

.....
These processes fall into line with the rest of the Light Aircraft in the UK with a CAA C of A. The CAA have confirmed that they will continue to accept BGA Motor Glider authorised engineers to certify C of A issue and renewal maintenance.

Patron
Vice Presidents

The Duke of Edinburgh KG
Christopher R Simpson MA LL.M
Roger Q Barrett
Tom Zealley BA PhD
Ben Watson MA FCA
Bill Walker OBE
Air Vice Marshal Don Spottiswood CB
Dick Dixon FCCII
Peter Hearne FREng MSc FRAeS

April 2001.

CIVIL AVIATION AUTHORITY

BGA. LEICESTER.

The completed application form should be forwarded to the ~~Civil Aviation Authority, Safety Regulation Group, Applications and Certification Section, Aviation House, Gatwick Airport South, West Sussex RH6 0YA~~ and must be accompanied by the appropriate charge in accordance with the current CAA Scheme of Charges.

APPLICATION FOR THE RENEWAL OF A CERTIFICATE OF AIRWORTHINESS/PERMIT TO FLY	
CERTIFICATE OF AIRWORTHINESS FOR AIRCRAFT ABOVE 15,000 KG OPERATING ON AN AOC	<input type="checkbox"/>
CERTIFICATE OF AIRWORTHINESS FOR AIRCRAFT BETWEEN 2,730 KG AND 15,000 KG AND FOR AIRCRAFT ABOVE 15,000 KG NON AOC	1 year <input type="checkbox"/> 3 year <input type="checkbox"/>
CERTIFICATE OF AIRWORTHINESS FOR AIRCRAFT BELOW 2,730 KG	<input type="checkbox"/>
PERMIT TO FLY	<input type="checkbox"/>
AIRCRAFT DETAILS	
Registration	Type
Serial No.	MTOW (Kg)
EXISTING CERTIFICATE OF AIRWORTHINESS/PERMIT TO FLY	
Category	Expiry Date
CHARGES (See Note 1)	FOR CAA USE
*The sum of £ is enclosed in payment of the statutory charges.	£
*Certificate of Airworthiness Validity Charges are covered by the Air Operators Certificate Charges Scheme.	Date
The aircraft is operated pursuant to AOC No.	Folio
Note 1: If the Certificate of Airworthiness or Permit to Fly has expired, a Subsequent Issue application on form CA3 must be submitted, however this will not be necessary unless the expiry period exceeds 12 months.	Rcvd by
ADDRESS DETAILS	
Name and address of Approved Organisation with whom aircraft is placed for the purpose of this application.	
BRITISH GLIDING ASSOCIATION KIMBERLEY HOUSE VAUGHAN WAY, LEICESTER Tel: Leicester 0116 2531051	
CAA Approval No. <u>DIA/8378/73</u>	
Place where aircraft may be surveyed:	
DECLARATION	
Name and address of applicant:	
Telephone No.	Facsimile No.
I hereby declare that to the best of my knowledge and belief the particulars entered on this application are accurate in every respect. The amount required by the current CAA Airworthiness Scheme of Charges to be paid on application is enclosed herewith. I also agree to pay any further charges in connection with this application in accordance with the said Scheme of Charges and which may be notified to me by the CAA.	
Date	Signature
FOR CAA USE ONLY	DATE RENEWAL ACKNOWLEDGED:
	SIGNATURE:

*Delete as applicable

